

**FEATURES:**

- Low Profile SMD (Surface Mount Device)
- 1000VDC & 6000VDC Isolation
- Industry Standard Pinout
- Unregulated Single, Dual, Dual Separated Output Models
- MTBF>1,000,000 hours
- Operating temperature: -40°C to +85°C ‡
- High Efficiency up to 85%



**Models**

**Single output**

Model	Input Voltage(V)	Output Voltage (V)	Output Current max(mA)	Isolation (VDC)	Efficiency (%)
AM2L-0515S-NZ	4.5-5.5	15	133	1000	84 ‡
AM2L-1205S-NZ	10.8-13.2	5	400	1000	82 ‡
AM2L-1212S-NZ	10.8-13.2	12	167	1000	85 ‡
AM2L-0505SH60-NZ	4.5-5.5	5	400	6000	76 ‡
AM2L-1205SH60-NZ	10.8-13.2	5	400	6000	76 ‡
AM2L-1215SH60-NZ	10.8-13.2	15	133	6000	79 ‡
AM2L-2405SH60-NZ	21.6-26.4	5	400	6000	77 ‡
AM2L-2412SH60-NZ	21.6-26.4	12	167	6000	80 ‡
AM2L-2415SH60-NZ	21.6-26.4	15	133	6000	78 ‡

‡ Please note Aimtec product change announcement located here [www.aimtec.com/news](http://www.aimtec.com/news) for product specification changes effective February 7<sup>th</sup> 2015.

**Models**

**Dual output**

Model	Input Voltage (V)	Output Voltage (V)	Output Current max (mA)	Isolation (VDC)	Efficiency (%)
AM2L-0505D-NZ	4.5-5.5	±5	±200	1000	82
AM2L-0509D-NZ	4.5-5.5	±9	±111	1000	83
AM2L-0512D-NZ	4.5-5.5	±12	±83	1000	84
AM2L-0515D-NZ	4.5-5.5	±15	±67	1000	82
AM2L-1205D-NZ	10.8-13.2	±5	±200	1000	83
AM2L-1209D-NZ	10.8-13.2	±9	±111	1000	84
AM2L-1212D-NZ	10.8-13.2	±12	±83	1000	84
AM2L-1215D-NZ	10.8-13.2	±15	±67	1000	85

**Models**

**Dual Separated output**

Model	Input Voltage (V)	Output Voltage (V)	Output Current max (mA)	Isolation (VDC)	Efficiency (%)
AM2L-050505D-NZ	4.5-5.5	5/5	200/200	1000	82
AM2L-050909D-NZ	4.5-5.5	9/9	112/112	1000	83
AM2L-051515D-NZ	4.5-5.5	15/15	67/67	1000	85
AM2L-120505D-NZ	10.8-13.2	5/5	200/200	1000	82
AM2L-121515D-NZ	10.8-13.2	15/15	67/67	1000	85

NOTE: All specifications in this datasheet are measured at an ambient temperature of 25°C, humidity<75%, nominal input voltage and at rated output load unless otherwise specified.

**Input Specifications**

Parameters	Nominal	Typical	Maximum	Units
Voltage range	5	4.5-5.5		VDC
	12	10.8-13.2		
	24	21.6-26.4		

### Isolation Specifications

Parameters	Conditions	Typical	Rated	Units
Tested I/O voltage	60 sec		1000, 6000	VDC
Tested V1 output/ V2 output	60 sec	1000		VDC
Capacitance V input/V output	500VDC	10		pF
Capacitance V1 output/V2 output	500VDC	10		pF
Resistance	500Vdc	>1000		MOhm

### Output Specifications

Parameters	Conditions	Typical	Maximum	Units
Voltage accuracy	See Tolerance Graph	±5		%
Short Circuit protection	1000VDC Momentary		1 sec	
	6000VDC Continuous			
Short Circuit Restart		Auto-Recovery		
Line voltage regulation	For a 1% change of Vin	±1.2		%
Load voltage regulation (5 Vout)	From 10% load to 100% load	12.8		%
Load voltage regulation (9 Vout)		8.3		
Load voltage regulation (12 Vout)		6.8		
Load voltage regulation (15 Vout)		6.3		
Temperature coefficient	At 100% load	±0.03		%/°C
Ripple & Noise*	20MHz Bandwidth	150		mV p-p
Minimum Load Current**		10		% of Max

\*Test ripple & noise by “Parallel Cable Method” as described in Application Note “Ripple and Noise Measurement of Brick & POL DC-DC Converters” available on Aimtec’s website [www.aimtec.com](http://www.aimtec.com)

\*\*If the operating output current is less than 10% of maximum it is recommended to install a load resistor in parallel with the load to ensure the actual load current meets the minimum load current requirement.

### General Specifications

Parameters	Conditions	Typical	Maximum	Units
Switching frequency	100% load, nominal input	100 ‡		KHz
Operating temperature		-40 to + 85 ‡		°C
Storage temperature		-55 to + 125		°C
Maximum case temperature			100	°C
Cooling		Free Air Convection		
Humidity			95	% RH
Case material		Plastic(UL94-V0)		
Weight	1000VDC	2.1		g
	6000VDC	3.8		
Dimensions (L x W x H)	Single, Dual, Dual Separated 1000VDC	0.70 x 0.70 x 0.24 inches	17.78 x 17.78 x 6.00 mm	
	Single 6000VDC	0.94 x 0.79 x 0.32 inches	23.86 x 18.50 x 8.00mm	
MTBF		>1,000, 000 hours (MIL-HDBK -217F, Ground Benign, t=+25°C)		
Maximum Soldering Temperature	1.5mm from case for 10 seconds		260	°C

### Safety Specifications

Parameters	
Agency approvals	CE (for 6000VDC isolation models)
Standards	EN 60601-1-1; EN 60601-1-2

**Pin Out Specifications**  
**1000VDC**

Pin	Single	Dual	Dual Separated
1	-Vin	- Vin	- Vin
2	+ Vin	+ Vin	+ Vin
5	NC	-Vout	-V1out
6	- Vout	Common	+V1out
7	+Vout	+Vout	NC
8	NC	NC	NC
9	NC	NC	+V2out
10	NC	-Vout	-V2out
12	NC	NC	NC
13	NC	NC	NC
14	NC	NC	NC

NOTE: On dual output models Pin 5 and Pin 10 are connected internally together. Either Pin 5 or Pin 10, or both can be used as the -Vout  
NC: not connected

**6000VDC**

Pin	Single
1	- V in
2	No Pin
3	No Pin
4	No Pin
5	No Pin
6	No Pin
7	NC
8	NC
9	+V out
10	-V out
11	No Pin
12	No Pin
13	No Pin
14	No Pin
15	No Pin
16	+V in

**Dimensions**  
**1000VDC**

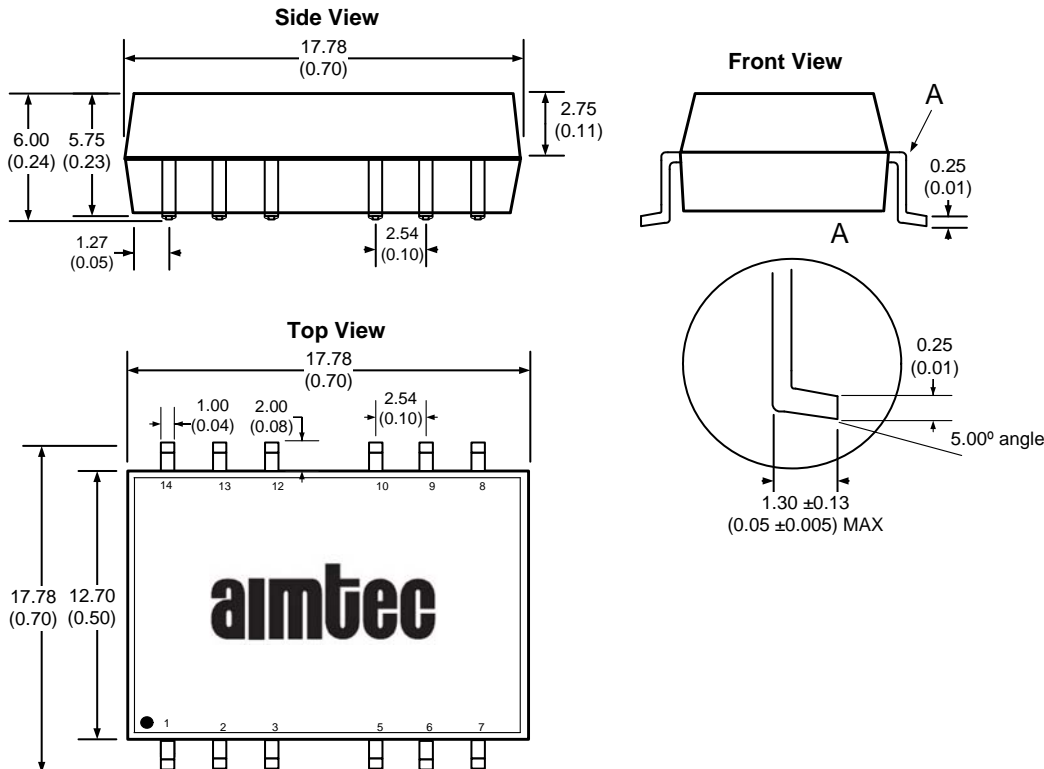

**Dimensions**  
**6000VDC**

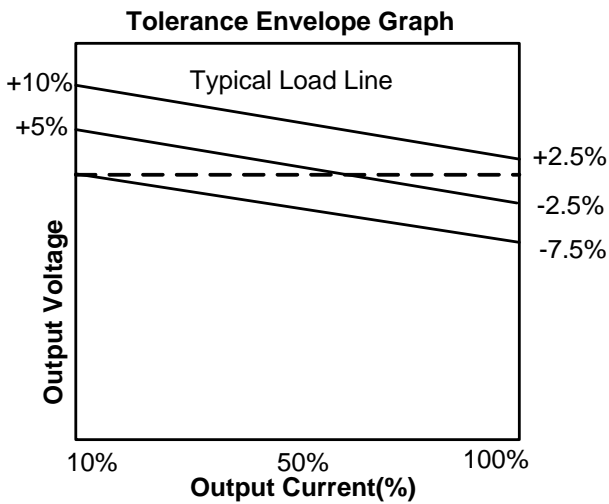
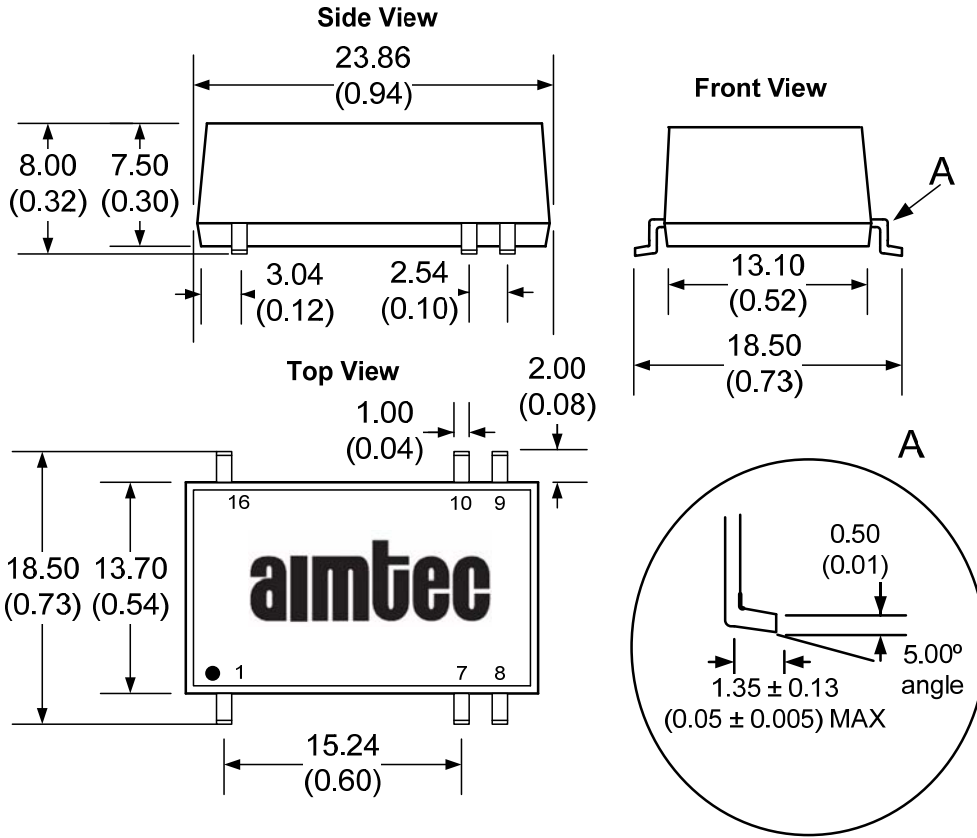

### Recommended Filter Circuit

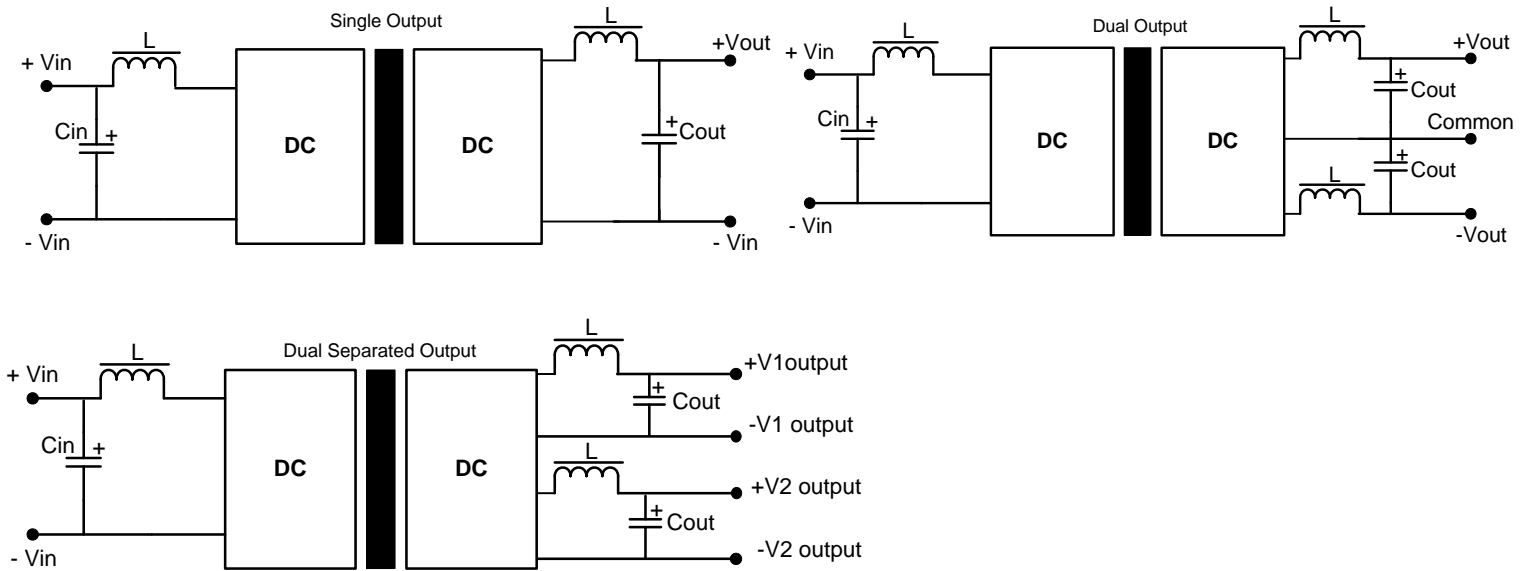

If it is required to decrease the input/output ripple an “LC” filter network can be installed on the input and output of the converter (see above).

It should be noted that the inductance and the resonant frequency of the “LC” filtering network should differ from the DC/DC converter switching frequency to avoid mutual interference.

The capacitance of the output filter capacitor must not exceed the values in the Table below to avoid startup problems and ensure safe and reliable operation.

**It’s not recommended to connect any external capacitor in the application field when output loading is less than 0.5 watt.**

### External Capacitor Tables

#### Input Capacitor (Cin)

Vin (VDC)	Cin (uF)
5	4.7
12	2.2
24	1

#### Output Capacitor (Cout)

Single Vout (VDC)	Cout (uF)	Dual Vout (Vdc)	Cout (uF)	Dual Separated Vout (Vdc)	Cout (uF)
5	10	±5	4.7	5/5	4.7
9	4.7	±9	2.2	9/9	2.2
12	2.2	±12	1	12/12	1
15	1	±15	0.47	15/15	0.47

### Overload Protection

The output circuit of these products has no protection against overload. It is recommended to install external overload protection in the form of a self-recovery fuse or a circuit breaker in series at the converter’s input.

To achieve a high degree of output voltage regulation, over-voltage, and over-current protection it is suggested to use the AM2LV-NZ series as an alternative.

**NOTE:** 1. Datasheets are updated as needed and as such, specifications are subject to change without notice. Once printed or downloaded, datasheets are no longer controlled by Aimtec; refer to [www.aimtec.com](http://www.aimtec.com) for the most current product specifications. 2. Product labels shown, including safety agency certifications on labels, may vary based on the date manufactured. 3. Mechanical drawings and specifications are for reference only. 4. All specifications are measured at an ambient temperature of 25°C, humidity < 75%, nominal input voltage and at rated output load unless otherwise specified. 5. Aimtec may not have conducted destructive testing or chemical analysis on all internal components and chemicals at the time of publishing this document. CAS numbers and other limited information are considered proprietary and may not be available for release. 6. This product is not designed for use in critical life support systems, equipment used in hazardous environments, nuclear control systems or other such applications which necessitate specific safety and regulatory standards other than the ones listed in this datasheet. 7. Warranty is in accordance with Aimtec’s standard Terms of Sale available at [www.aimtec.com](http://www.aimtec.com).